

Installation Instructions

Models: KF3S and KF3P

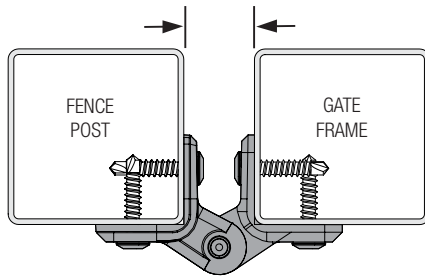

IDEAL GATE GAP
3/4" (19mm)



COMPLETED INSTALLATION

Note: The gap between the post and gate frame must be 3/4" (19mm).

Note: Use 10-gauge screws or bolts only. Consult your local hardware store for fastener options. Do not use countersinking screws or attempt to countersink the hinges.

Max. Gate Weight	Max. Gate Dimensions
KF3S: 45 lbs [20kg]	5'H x 3'W (1524x915mm)
KF3P: 55 lbs [25kg]	5'H x 3'W (1524x915mm)

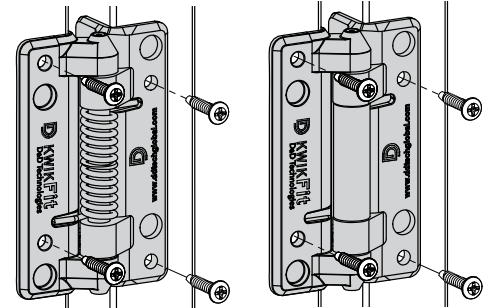

KF3S
(With spring. Self-Closing)

KF3P
(Plain pivoting. Non Self-Closing)

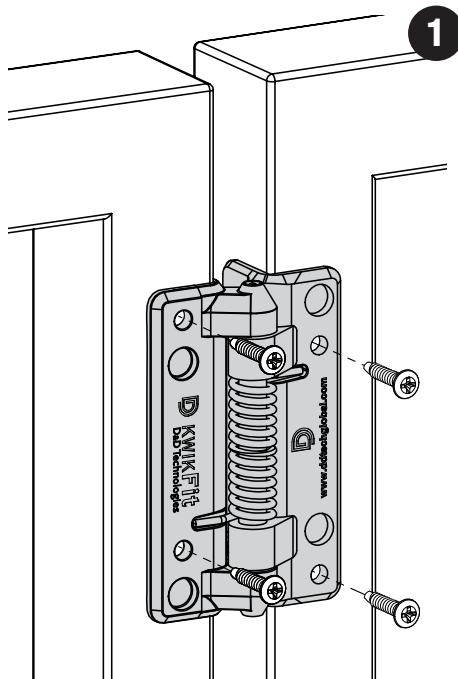

WITH GATE CLOSED
(FRONT OF GATE)

1

MOUNTING TO THE FRONT FACE

The side-fixing legs on each hinge provide double face-fixing and allow quick alignment onto the gate and post. Choose the desired height of the hinge placement. Mark with a pencil if necessary. While holding the top hinge in place (use support blocks under the gate if required) take eight 10-gauge screws and secure top and bottom hinges to the front face, as shown at left.

2

MOUNTING THE SIDE-FIXING LEGS

With the hinges secured to the front face, move around to the opposite side and open the gate. Take more 10-gauge screws and secure the side-fixing legs on both top and bottom hinges, as shown at right.

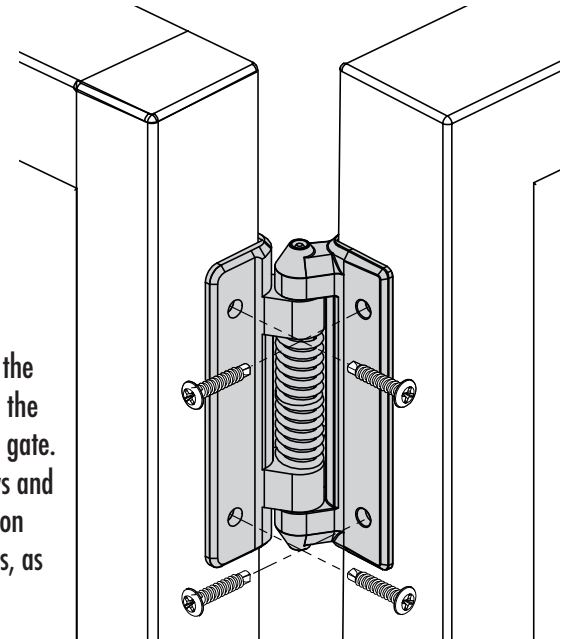

WITH GATE HALF OPEN
(OTHER SIDE)

CAUTION:

The hinges will operate properly, and warranty is valid, only if installed in accordance with the instructions and specifications shown herein.

MAINTENANCE REQUIREMENTS:

- Ensure the gate does not swing through the line of the fence (180°). Use a "gate stop" or a latch (with striker) to prevent this.
- Remove all existing hinges and self-closing devices.
- Ensure the hinges are kept free of sand, ice and other debris that could impair effective operation.
- Do not disassemble these hinges at any time.
- Do not paint or apply any additional finishes to the hinges.
- Never remove hinges from gate while under spring tension.
- Do not lubricate these hinges with petroleum-based lubricants at any time. Use only powdered graphite.
- Do not physically cut, drill, countersink, machine or grind any part of the hinges
- If through-bolts are used, remove excess bolt by cutting, grinding and/or filing.

LIMITED LIFETIME WARRANTY

For a downloadable PDF version of the Warranty go to our website